

TVV1 Multi-Standard Video Decoder Core

Summary

The Albacores TVV1 IP core is an extremely robust, high-quality, silicon-efficient analog video decoder. It accepts digitized video from ADCs (analog-to-digital converters), automatically determines the video standard in use, and decodes NTSC, PAL, and SECAM analog TV signals using advanced adaptive 2D and 3D comb filters. It accepts composite, S-Video, and YPbPr (component) video in both interlaced and progressive formats. It includes an advanced VBI data decoder and a time base corrector, providing excellent VCR and weak-signal performance.

The TVV1 provides significant benefits compared to other video decoders. It produces better video quality for a wider variety of video sources. Due to fewer external components being required, design time, design risk, and total system cost are significantly reduced. The TVV1's advanced video locking capabilities and ability to automatically detect the video standard result in less CPU overhead, less real-time CPU requirements, and a better overall user experience.

Some of the advanced features of the TVV1 include pixel-by-pixel adaptive 2D/3D comb filtering, extremely robust H- and V-Sync locking, an internal anti-aliasing filter, and two-stage control of the input gain and DC offset (external coarse-grain control with internal fine-grain processing).

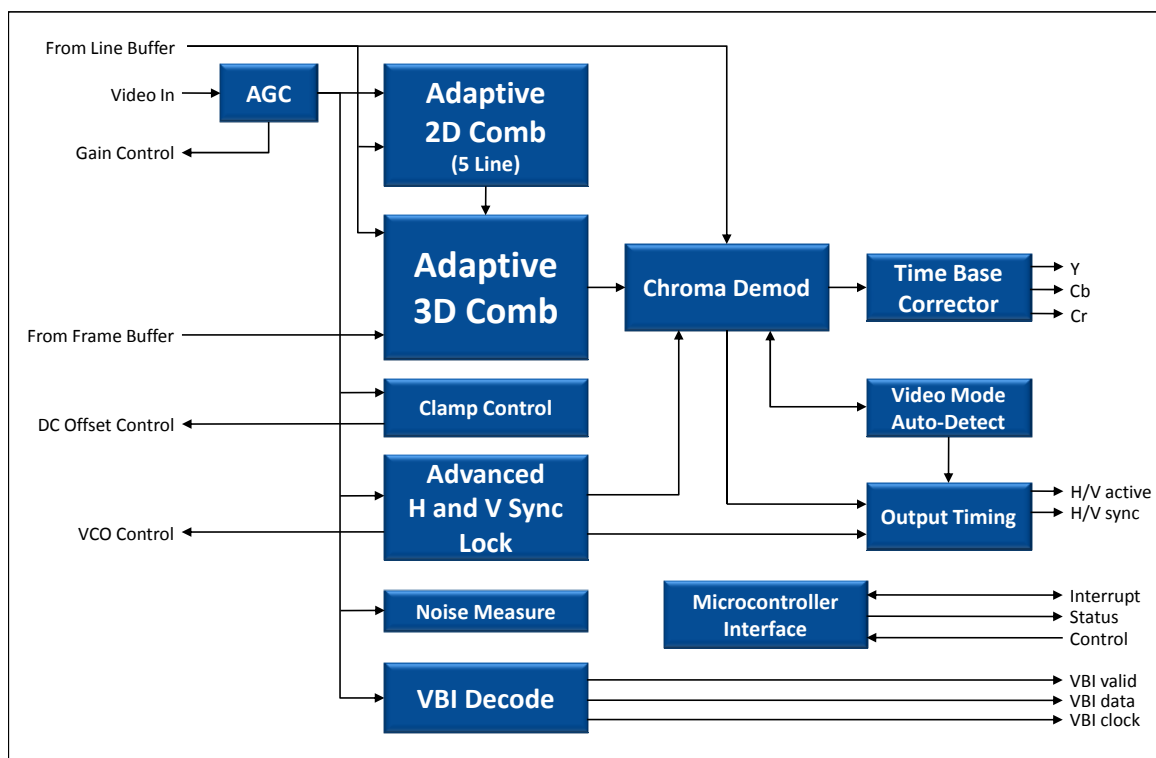

TVV1 Top-Level Architecture

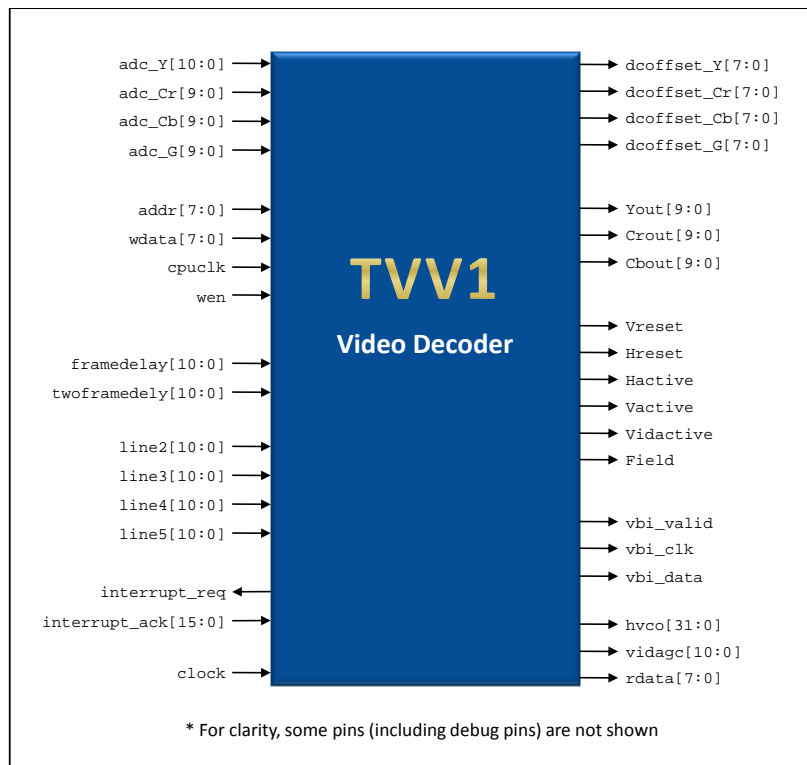

TVV1 Pin-Out

Features

- Adaptive 5-line 2D and adaptive 3D
- NTSC compatibility: J, M, 4.43
- PAL compatibility: B, D, G, H, I, M, N, Combination N, 60
- SECAM compatibility: B, D, G, K, K1, L
- Automatic standards detection in hardware
- Works with 2-head VCRs in all trick modes and all tape speeds
- Anti-aliasing filter
- Macrovision detection
- Programmable auto color killer level
- Blue screen mode on loss of valid signal
- Programmable IF compensation HP filter
- TBC ± 400 pixels
- HSYNC lock range ± 750 Hz from normal
- Sync height to acquire/maintain lock: 12% / 5%
- VBI data slicer:
 - Handles CC, Teletext, GMS, WSS
 - Extracts VBI data from Y signal for S-Video and component (YPbPr)

Deliverables

- Synthesizable Verilog RTL
- Verilog testbench
- Detailed product documentation
- Design specifications
- Integration guidelines
- Complete verification suite
- VHS tape with example noisy signals
- Extensive tests including corner-case scenarios
- Golden test result vectors
- FPGA test board (with testbench and supporting files)

For more information, contact sales@albacores-ip.com +1-650-488-4484